

SYNERGY

ASSEMBLY MANUAL
PANEL TO POST UNION 180°

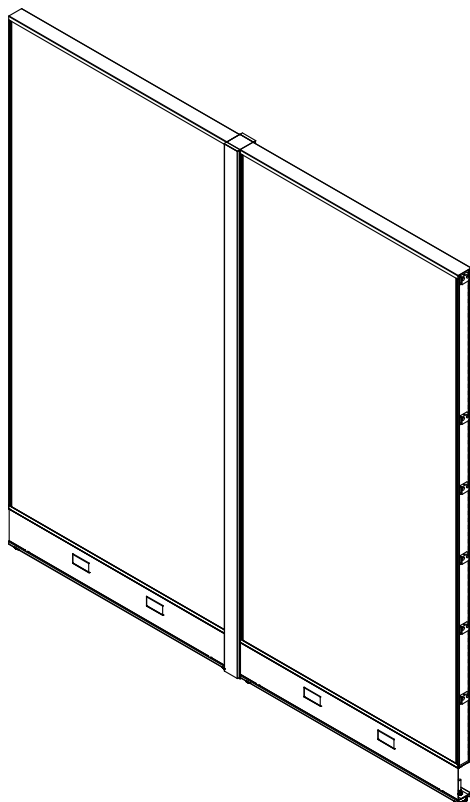

Gebesa
CREATING AMAZING SPACES

Questions?

Call Toll Free +1-505-620-5666 or email warranty@gebesa.com

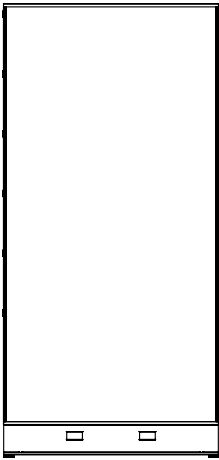

Panel
(A)
2x



Multi-ways post
(B)
1x



End cap
(C)
2x



*All the end caps
have an integrated bolt

FASTENERS



1/4" x 2" Allen Screw
(D)
2x

Wedge System

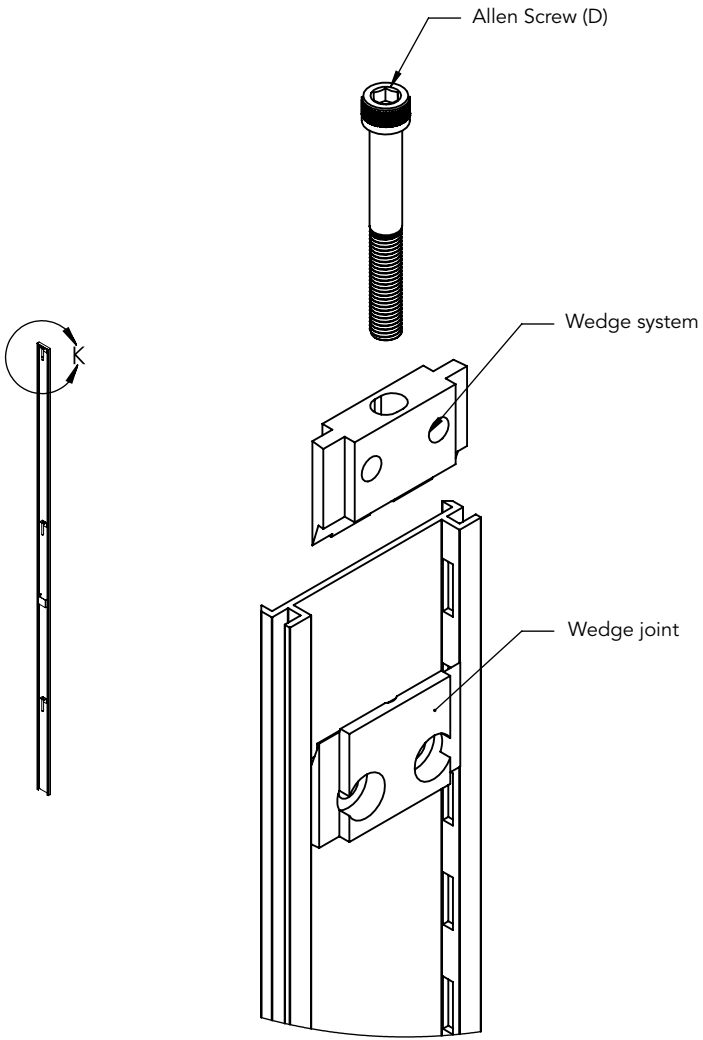

Detail K

1. Adjust the bulkhead levelers to 3/4 inch. height.

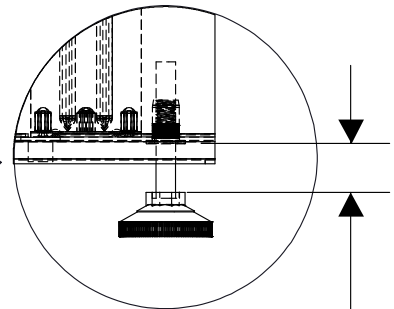
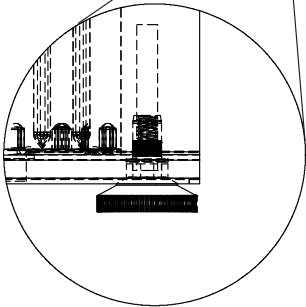
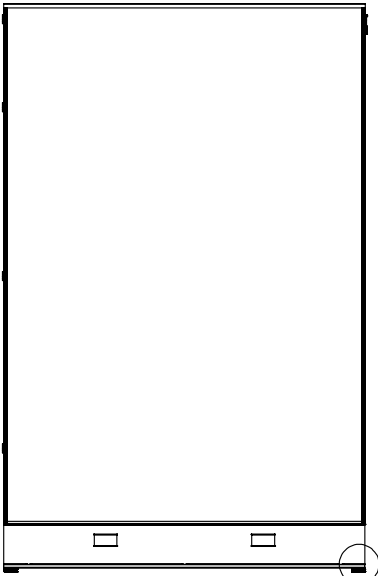

19 mm
3/4"

2. Remove the End caps as well as the Top cap from the panel; align the Multi-ways Post (B) to the side of the panel.

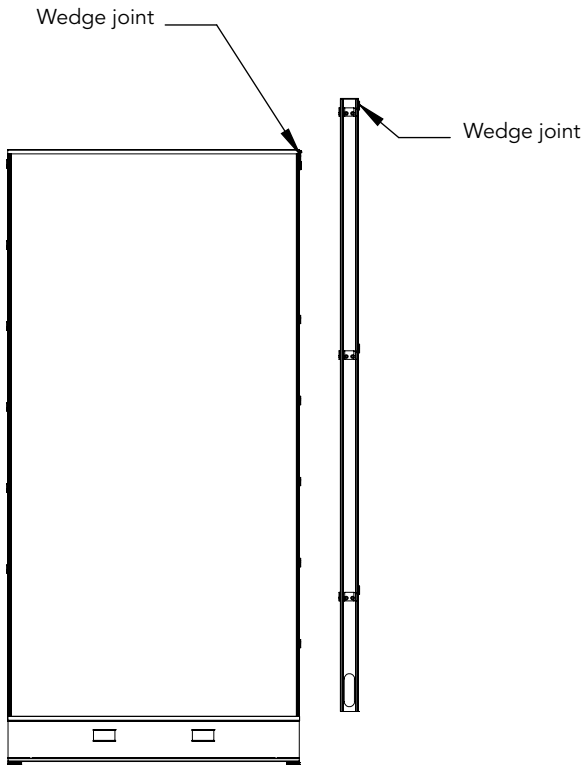

3. Using the Wedge System, place the Wedge Joints of the Panel and the Post together, use the 1/4" x 2" Allen Screw (D) to fix them.

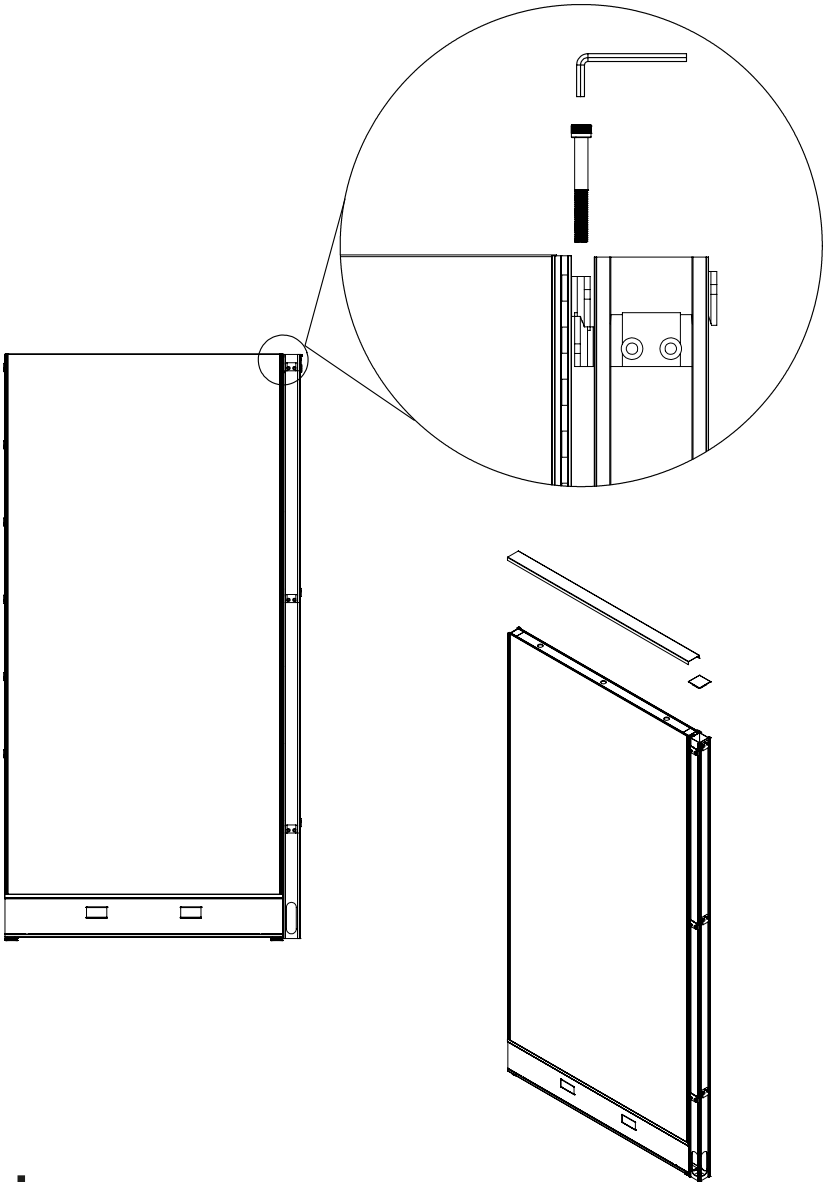

4. Repeat the process of the Wedge System to fix the first Panel with the Post to the second Panel.

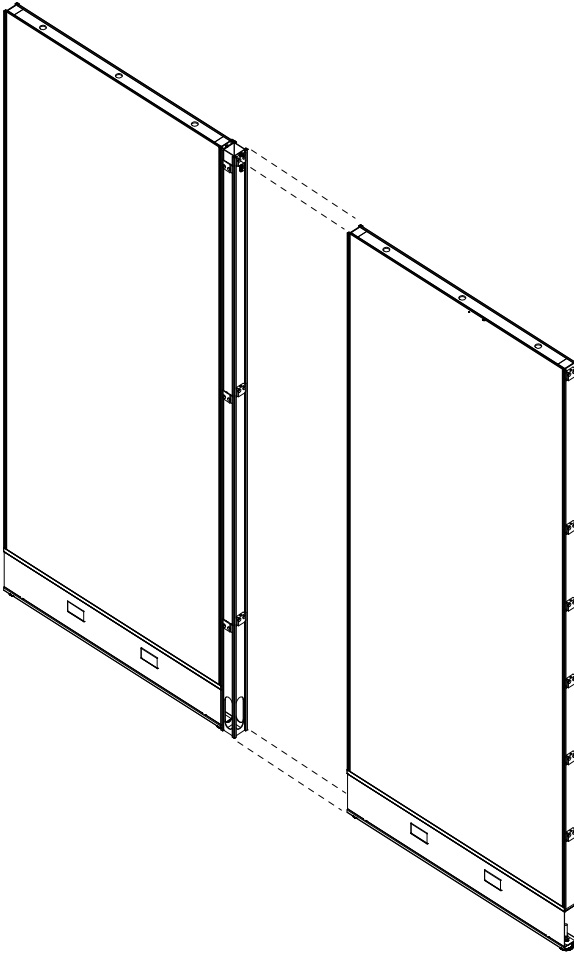

5. Place the End Caps (C) to cover the Post (B) spaces.

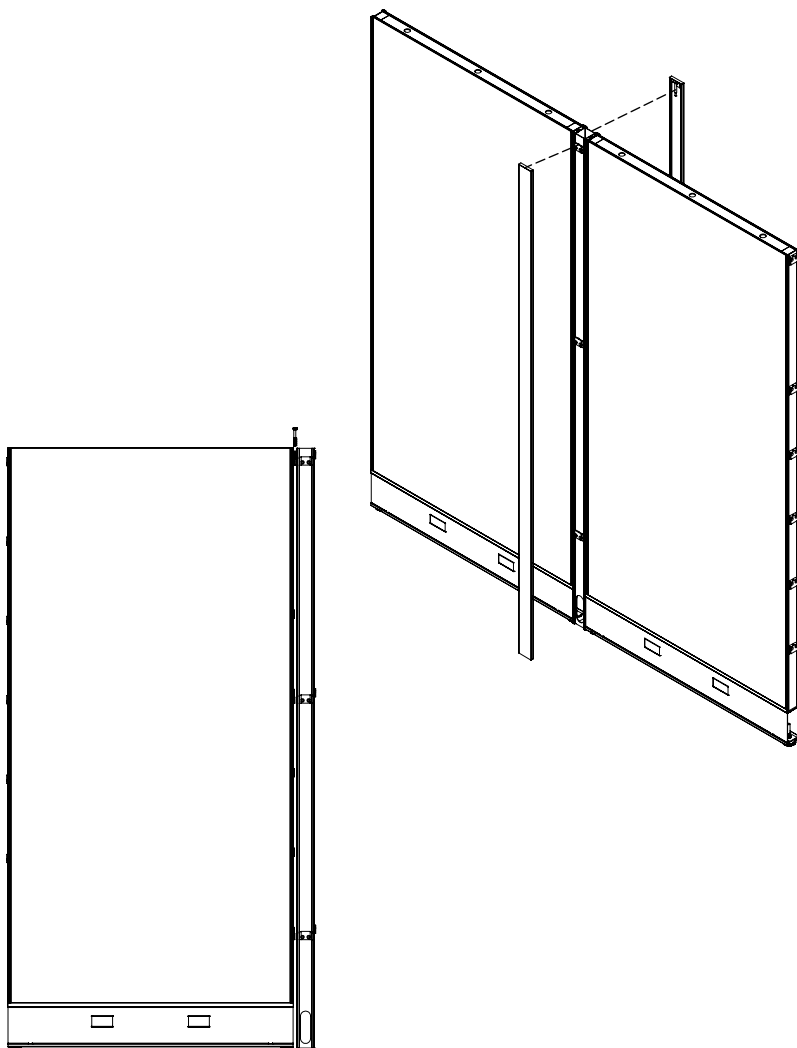

6. Place the Top Caps and make sure assembly is stiff and stable.

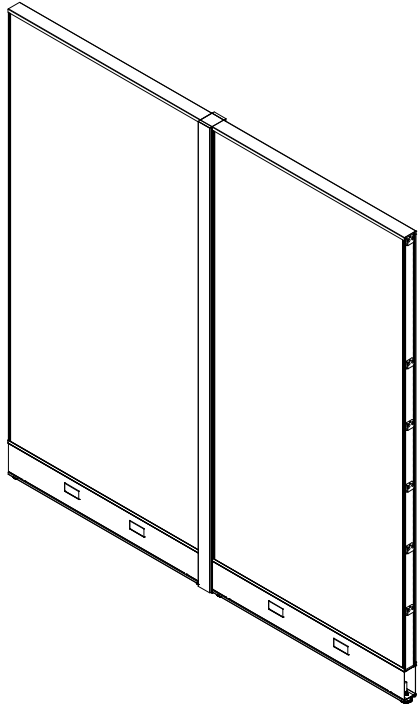
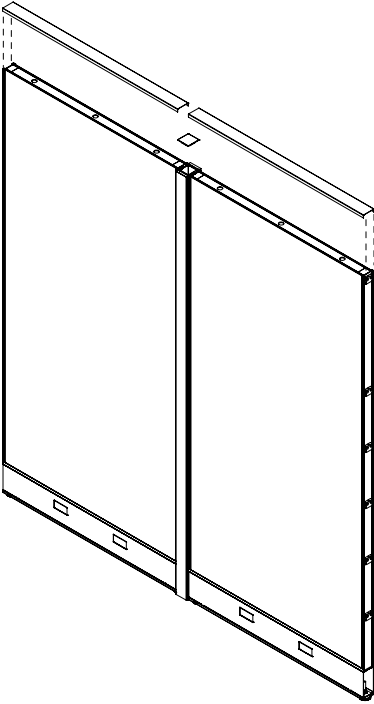

Questions?

Call Toll Free +1-505-620-5666
or email warranty@gebesa.com

Gebesa
CREATING AMAZING SPACES

Gebesa
CREATING AMAZING SPACES