

# SYNERGY

ASSEMBLY MANUAL  
WORKSURFACE TO PANEL

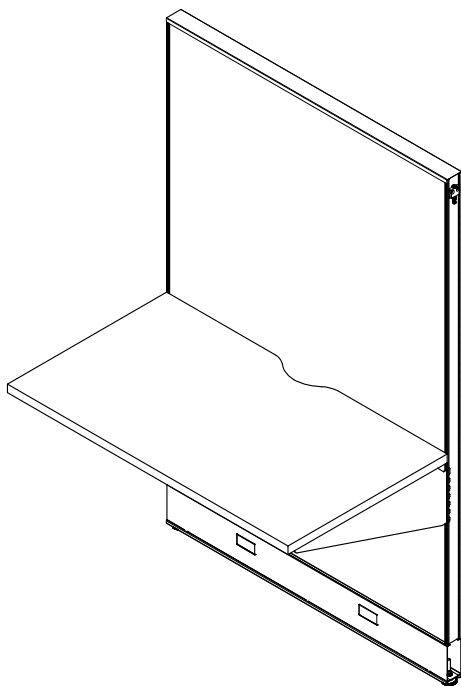

**Gebesa**  
CREATING AMAZING SPACES

Questions?

Call Toll Free +1-505-620-5666 or email [warranty@gebesa.com](mailto:warranty@gebesa.com)

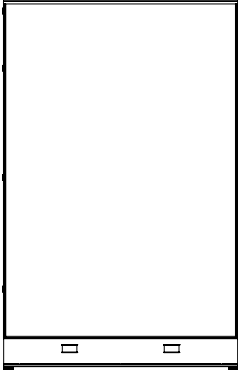

Panel  
(A)  
1x

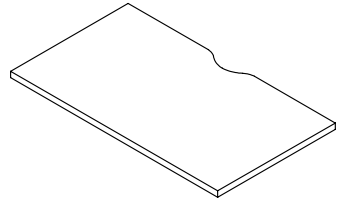

Worksurface  
(B)  
1x

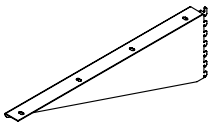

Left base bracket  
(C)  
1x

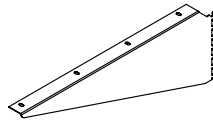

Right base bracket  
(D)  
1x

FASTENERS



#8 x 1" Self-Tapping Screw  
(E)  
8x

1. Tilt the base bracket (C,D) hooks towards the panel at the standard height (2.95') or at the desired height contemplating 1.11' of the worksurface.

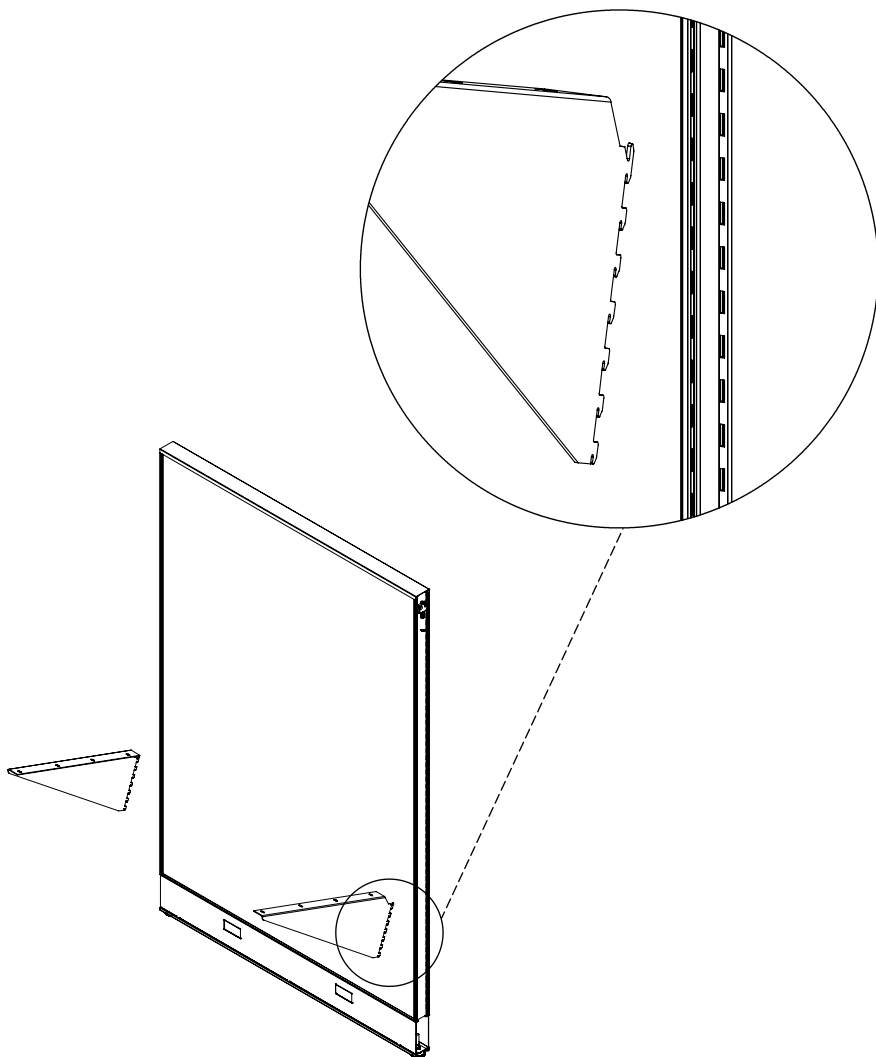

2. Insert the tip of the base bracket's hooks (C,D) into the slots of the panel (A).

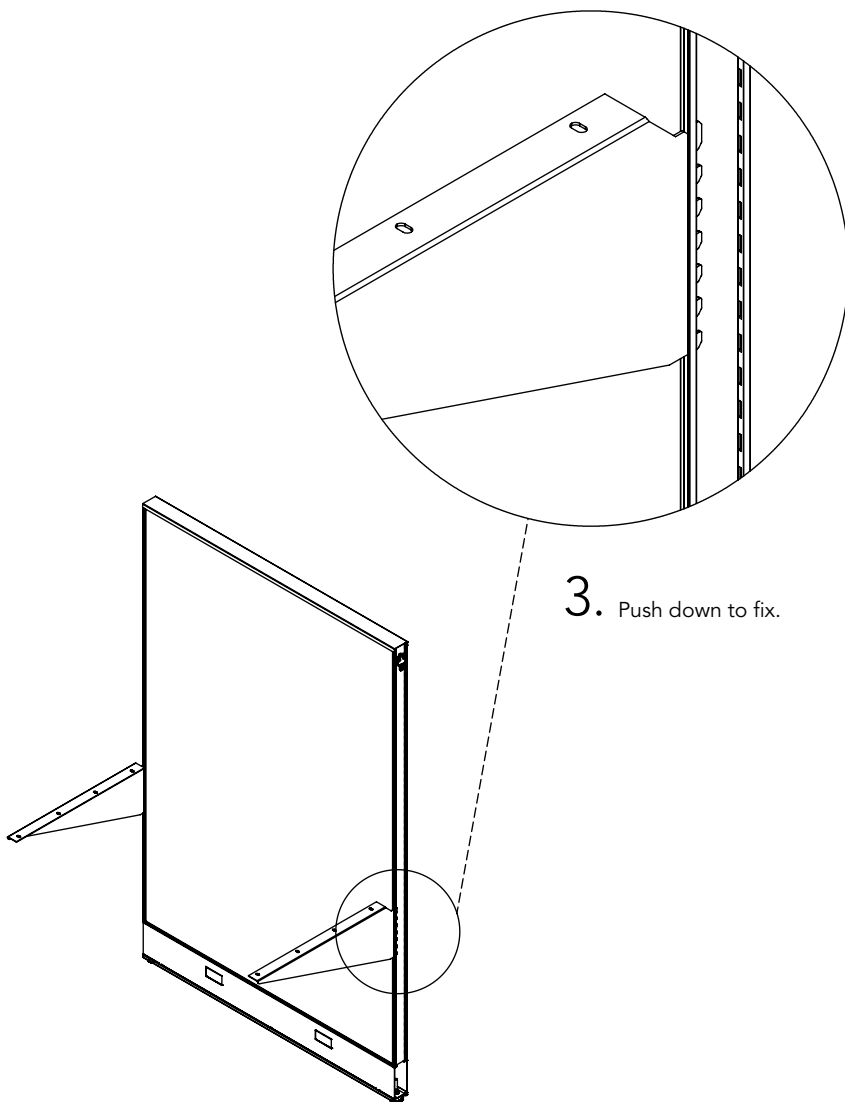

3. Push down to fix.

4. Place and align the worksurface on top of the fixed brackets.

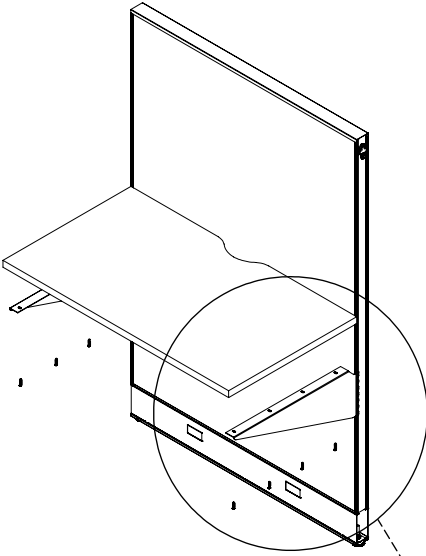

5. Use the #8 x 1" screw (D) to fix the worksurface (B) to the left and right base brackets (C,D).

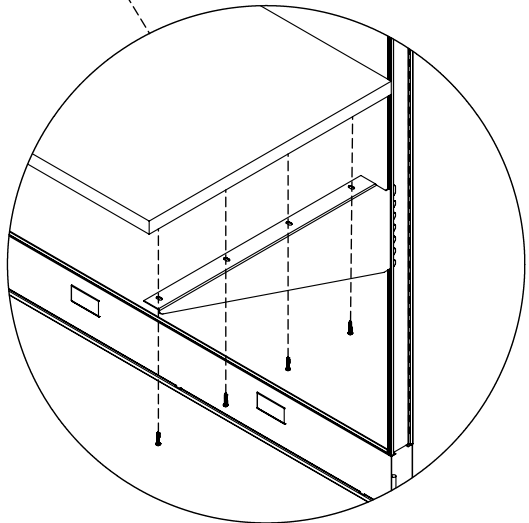

6. Make sure assembly is stiff and stable.

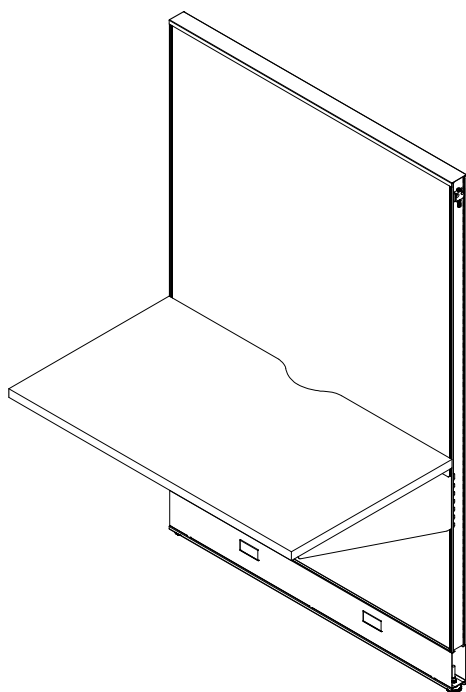

Questions?

Call Toll Free +1-505-620-5666  
or email [warranty@gebesa.com](mailto:warranty@gebesa.com)

**Gebesa**  
CREATING AMAZING SPACES

**Gebesa**  
CREATING AMAZING SPACES